

**Xtera**  
**Successful Story of**  
**Platform**

Xtera Communications, Inc. The Application-optimization Provider

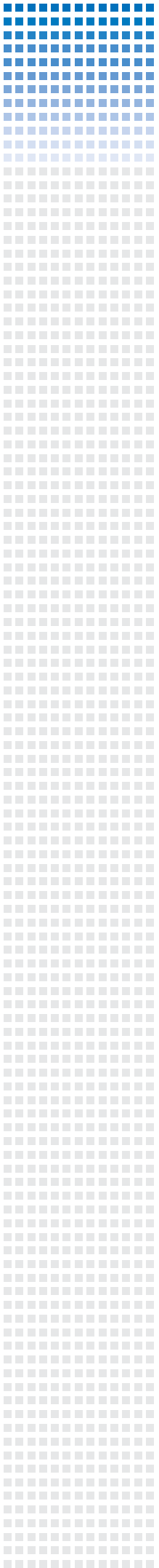



**X T E R A**

## **Background**

Platform Computing is a pioneer and the global leader in High Performance Computing (HPC) infrastructure software. The company delivers integrated software solutions that enable organizations to improve time-to-results and reduce computing costs. Many of the world's largest companies rely on Platform for workload management and cluster and grid management. Platform has over 2,000 global customers and strategic relationships with Dell, HP, IBM, Intel, Microsoft, Red Hat and SAS, along with the industry's broadest support for HPC applications. Building on 15 years of market leadership, Platform continues to define the HPC market.

Platform is headquartered in Toronto, Canada with sales offices and research and development centers in key locations around the world including Beijing and Xian. To facilitate the management of data from each research and development center and to ensure the security of data transmission, Platform uses centralized data management and VPN gateway for IPsec point-to-point tunnel connection.

## **Challenge**

Platform's data center is located in Beijing. Daily data synchronization takes place between the data center and research and development centers such as Toronto and Xian via VPN. Prior to deploying AscenLink, Platform's network was not equipped with multiple link integration. Neither the VPN nor the centralized data management were able to perform to their maximum potential. And there were certain risks in network security:

1. VPN gateway's tunnel could not be established across multiple WAN links; data synchronization did not make full use of multiple Internet lines at the headquarters and branch offices.
2. Some branches used a single Internet line, so the WAN link was unstable and did not ensure the stability and timeliness of data synchronization. Getting an additional line and the maximum return on investment were the utmost concern.
3. Important data synchronization traffic and Internet traffic shared bandwidth; thus, making bandwidth available to data synchronization was a priority.

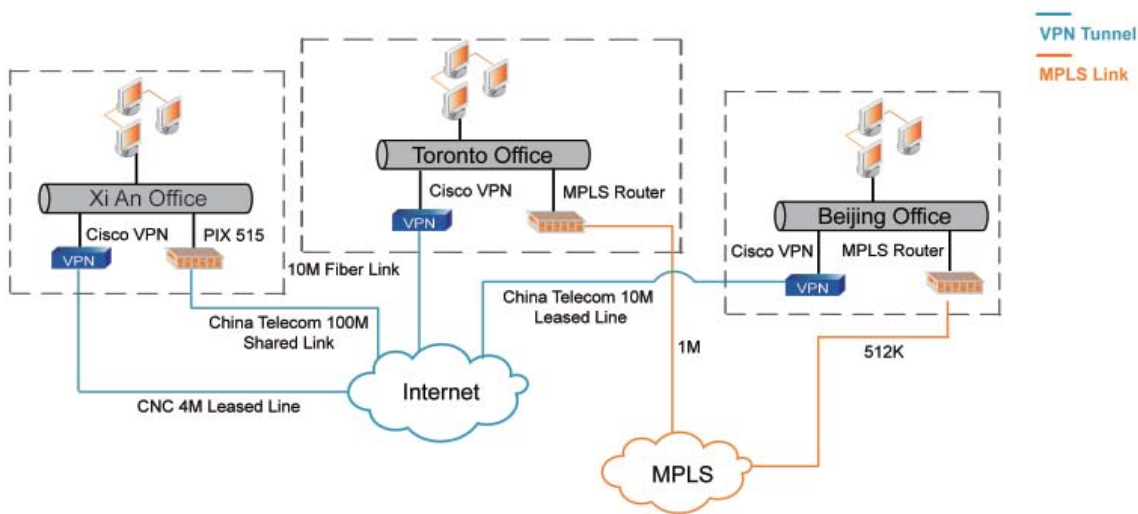

Network Topology before AscenLink deployment

## Solution

Platform deployed an AscenLink on each site in Toronto, Beijing, and Xian to aggregate multiple WAN links. The solution is detailed below:

1. Tunnel Routing makes it possible to create VPN connections from the current VPN gateway over multiple WAN links, thereby aggregating multiple Internet links of the branch offices to make full use of each WAN link's bandwidth for improved speed of data transmission and data synchronization.
2. Tunnel Routing supports dynamic IP connections (such as ADSL and DHCP) while allowing the establishment of a VPN tunnel over a static IP; therefore, Platform is able to expand its network by using low cost ADSL links.
3. AscenLink's Tunnel Routing is equipped with network health checks to monitor the status of each WAN link. When every link is normal, traffic is load balanced evenly among all available tunnels via load balance algorithms. Upon the detection of a failed link, the traffic will be routed to a normal link.
4. AscenLink's Bandwidth Traffic Management can allocate bandwidth for tunnel traffic and Internet traffic; when VPN and Internet traffic share a WAN link, tunnel and data synchronization traffic can be assigned sufficient bandwidth to ensure stability and accuracy for data synchronization.



# XTERA

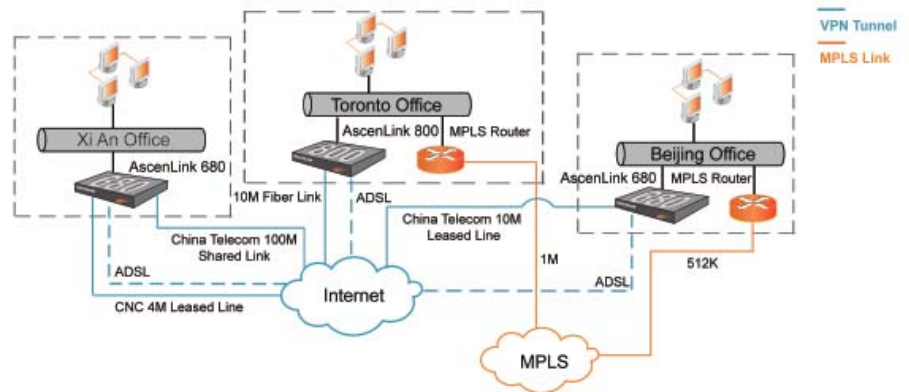

Network Topology after AscenLink deployment

## Benefits

AscenLink's transparent network management mechanism enables drop-in deployment and requires no changes to the existing network configuration. It has been praised as the best price/performance network solution by customers. AscenLink's exclusive, patented Tunnel Routing solves the problem of VPN unreliability and instability. Tunnel Routing played a significant role in the solution to Platform's network challenges.

After repeated testing, Platform's IT team determined that AscenLink can serve as a VPN gateway for multiple link load balancing, and nearly accomplishes having WAN perform as well as LAN. Data synchronization can be made fast and secure by AscenLink. Moreover, AscenLink enables building VPN tunnels in dynamic IP network environment; therefore, Platform can achieve bandwidth expansion and network expansion with multiple ADSL links and reduce network costs.

## Return on Investment

AscenLink helped Platform perfect its VPN by making VPN stable and eliminating the risk of VPN single link failure. AscenLink also helped speed up data transmission and improve efficiency of data synchronization.

Ahmed Shariff, Platform's Director, Information Technology, said: "We had challenges in some of Platform offices where we had a number of ISP connections but not all of them were reliable. When we heard about the Tunnel Routing technology from Xtera Taiwan, naturally we were excited. You can have several physical ISP links and group them into one logical tunnel link. At any given time one of the several physical links can go down, but the tunnel will still stay up."

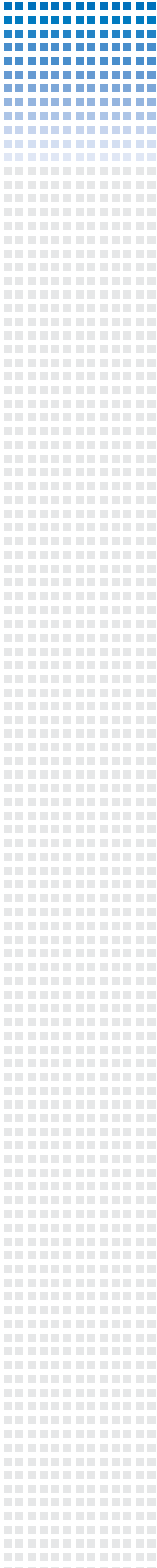

“After extensive evaluation, Platform has deployed AscenLink, the Intelligent WAN Load Balancer, in our offices. The result as expected, ‘no downtime due to Internet link outage’” Shariff added.

Moreover, AscenLink is a worthwhile network investment and has helped Platform improve its network services: multiple links are being used to their potential; data synchronization is taking place on more capable and secure links; centralized data management is saving human resources and IT equipment costs. Therefore, AscenLink becomes the best choice and solution to Platform’s case for network improvement.

### ***About Xtera Communications***

Xtera Communications provides network solutions enabling communications companies to profitably deliver high-bandwidth tailored services at the lowest sustainable cost per bit. Xtera delivers value by combining sound business practice with compelling advantages in capacity, reach, simplicity and service. Further information is available online at [www.xtera.com](http://www.xtera.com).

### ***About Xtera’s IP Division***

AscenVision Technologies was founded in August, 2000, and acquired by Xtera in October, 2007 and became Xtera’s IP Division. The IP Networking Division uses innovative L4-L7 WAN solution to provide comprehensive, world-class solutions for network management, security, and performance. Visit [www.xtera-ip.com](http://www.xtera-ip.com) for more information.